

空气管头

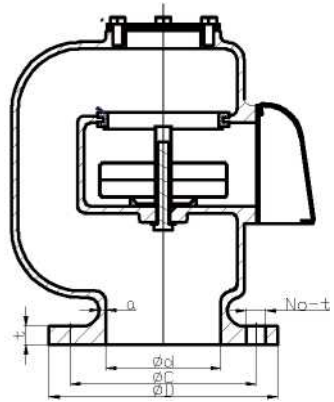

材料表/Materials Table

序号	零件名称	材料	NAME OF PART	MATERIAL
1	阀体	HT200	BODY	FC200
2	浮筒	1Cr18Ni9Ti		SUS304
3	密封圈	丁腈橡胶	Packing	NBR
4	滤网	Q235A(内有 1Cr18ni9Ti)	Strainer	SS400(SUS304)

尺寸表/Size Table

DN	d	D	C	h	hole
50A	50	130	105	4	15
65A	65	155	130	4	15
80A	80	180	145	4	19
100A	100	200	165	8	19
125A	125	235	200	8	19
150A	150	265	230	8	19
200A	200	320	280	8	0 23
250A	250	385	345	12	23
300A	300	430	390	12	0 23
350A	350	480	435	12	0 23
400A	400	540	495	16	0 25
450A	450	605	555	16	25

尼古拉空气管头

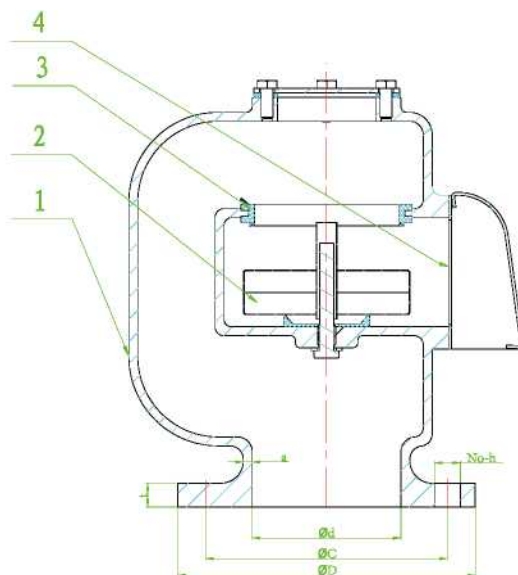

材料表/Materials Table

序号	零件名称	材料	NAME OF PART	MATERIAL
1	阀体	HT200	BODY	FC200
2	浮筒	1CM8	Float	SUS304
3	密封圈	丁腈橡胶	Packing	NBR
4	滤网	Q235A (Q235/SUS304)	Strainer	SS400(SUS304)

尺寸表/Size Table

DN	d	D	C	h	hole
50A	50	130	105	4	15
65A	65	155	130	4	15
80A	80	180	145	4	19
100A	100	200	165	8	19
125A	125	235	200	8	19
150A	150	265	230	8	19
200A	200	320	280	8	23